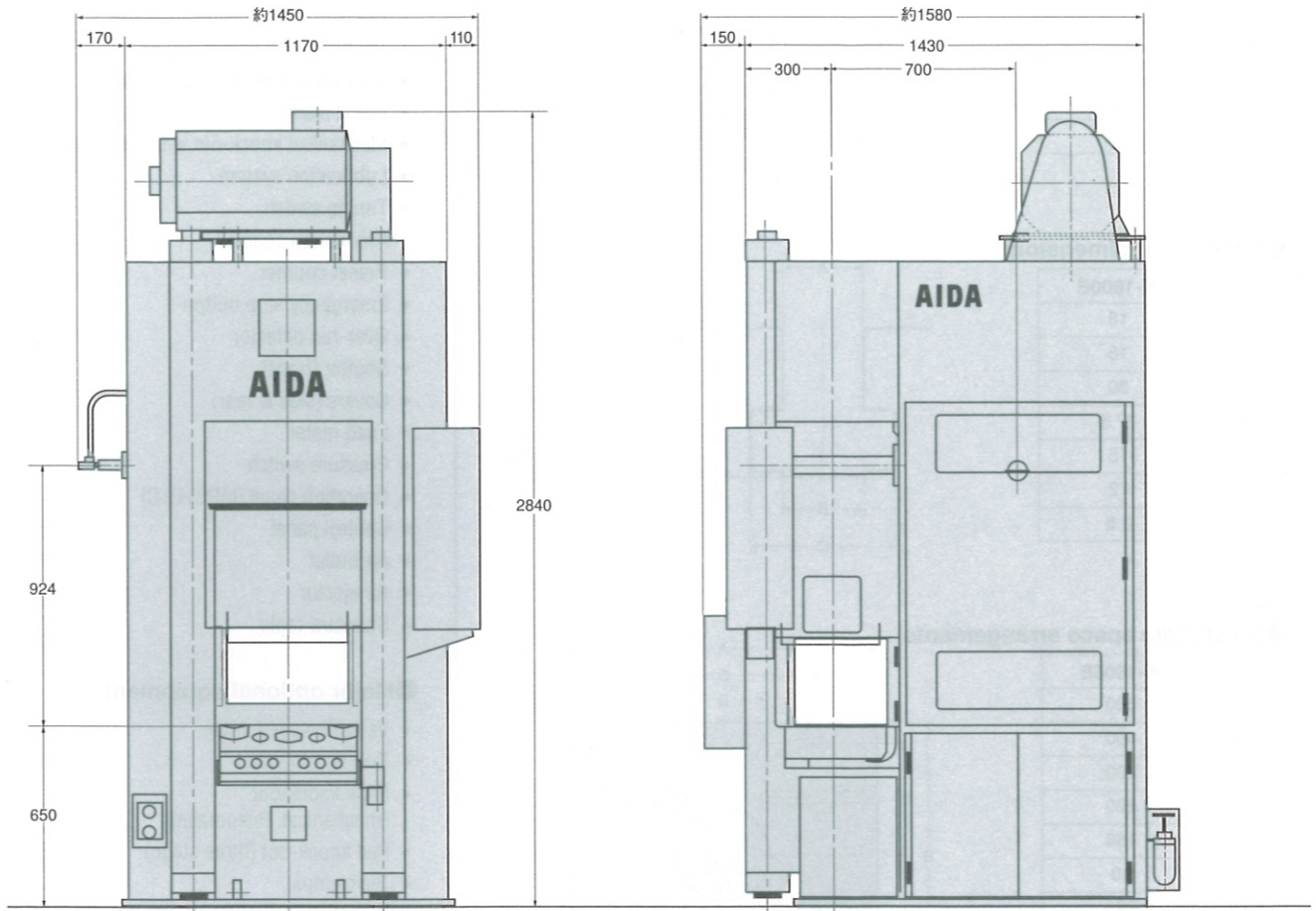

**●Major Dimensions of K1-1600E (Approx.)**

**●Principal Specifications**

Model		K-1600E
Tonnage capacity	(kN)	1600
Rated tonnage point	(mm)	4
Slide stroke	(mm)	90
Strokes per minute under no load	(spm)	65 (35~65)
Die-height	(mm)	300
Slide adjustment	(mm)	15
Slide area (L.R.×F.B.)	(mm)	450×350
Bolster area (L.R.×F.B.)	(mm)	500×400
Side opening	(mm)	415
Bed Knockout capacity	(kN)	80
Knockout stroke	(mm)	45 (10)
Overall height above floor level	(mm)	2840
Main motor	(kW)	11 (15 V.S)

※Specifications in ( ) are also available optionally.

※Variable-speed drive is optionally available.

※The specifications in this brochure are subject to change without notice.

**● Slide die space arrangements**

K-1600E	
A	450
B	350
C	160
D	200
φE	166
φF	20

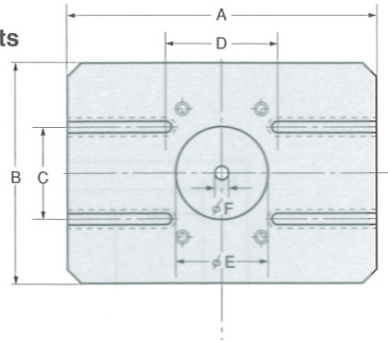
**● Slide T-slot dimensions**

K-1600E	
A	18
B	18
C	30
D	27.5
E	15
F	12
G	0.5

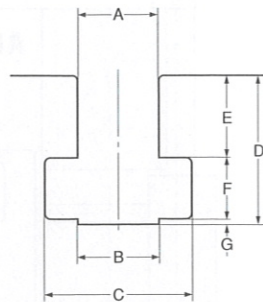
**● Bolster die space arrangements**

K-1600E	
A	500
B	400
C	200
D	200
φE	166
φF	40
G	270
H	180
φI	25

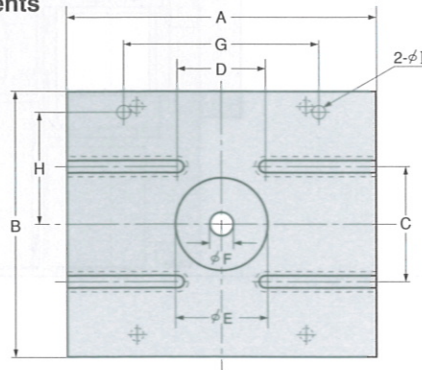
**● Bolster T-slot dimensions**

K-1600E	
A	22
B	22
C	37
D	36
E	19
F	16
G	1

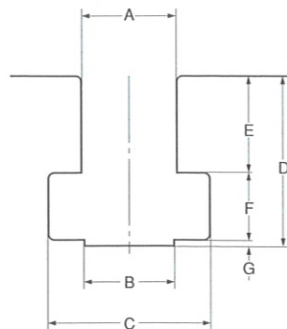

※The specifications may be changed without notice.

**● Major standard equipment**

- Reversing starter
- Micro-inching
- Flywheel brake
- Electronic crank angle indicator
- Die height indicator
- Stand-type operation button box
- Insert plate
- Mechanical knock-out within the bed
- Lubrication system
- Timing switch
- Production counter
- Preset counter
- Emergency stop button
- Over-run detector
- Shutter (front)
- Covers (side & rear)
- Load meter
- Pressure switch
- Operation panel (MPC+PLC)
- Control panel
- Air outlet
- Air ejector
- Standard tools

**● Major optional equipment**

- Variable-speed drive
- Run button stand
- Slide knock-out (mechanical, Pneumatic)
- Bed knock-out (three stage)
- Die clamps
- Die lifter
- Graphic load meter
- Optical safety device
- Warning lamp on top of press
- Die-room light
- Automation device
- Air pressure intensification valve
- Two dimensional transfer unit (mechanical)
- Three dimensional transfer unit (servo type)
- Product discharge conveyor
- Material feed device
- Die set
- Anit-vibration mount
- Anchor bolts

※More attachments are prepared than the specifications shown above. Please contact AIDA for further information.

**AIDA ENGINEERING, LTD. (JAPAN)**

2-10 Ohyama-cho, Sagamihara, Kanagawa 229-1181, Japan.  
 Phone: (81)42-772-5258 Facsimile: (81)42-758-1169  
 Homepage Address: <http://www.aida.co.jp/>

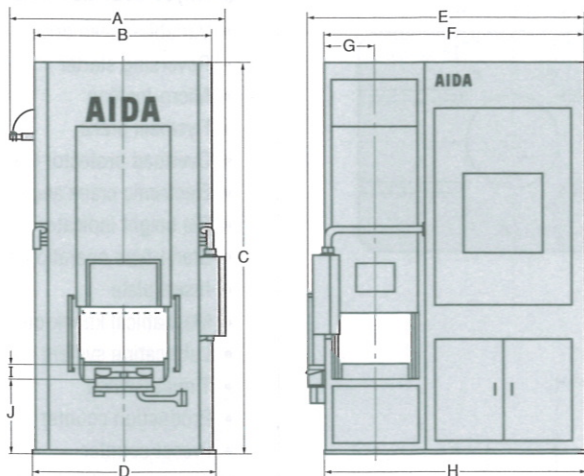
**●Major Dimensions of K1-2500E, K1-4000E, K1-6300E (Approx.)**

	K1-2500E	K1-4000E	K1-6300E
A	1680	1910	2140
B	1300	1540	1760
C	3040	3555	4265
D	1330	1570	1790
E	2170	2445	3020
F	2000	2310	2840
G	390	460	560
H	2030	2340	2870
I	130	140	150
J	570	660	770

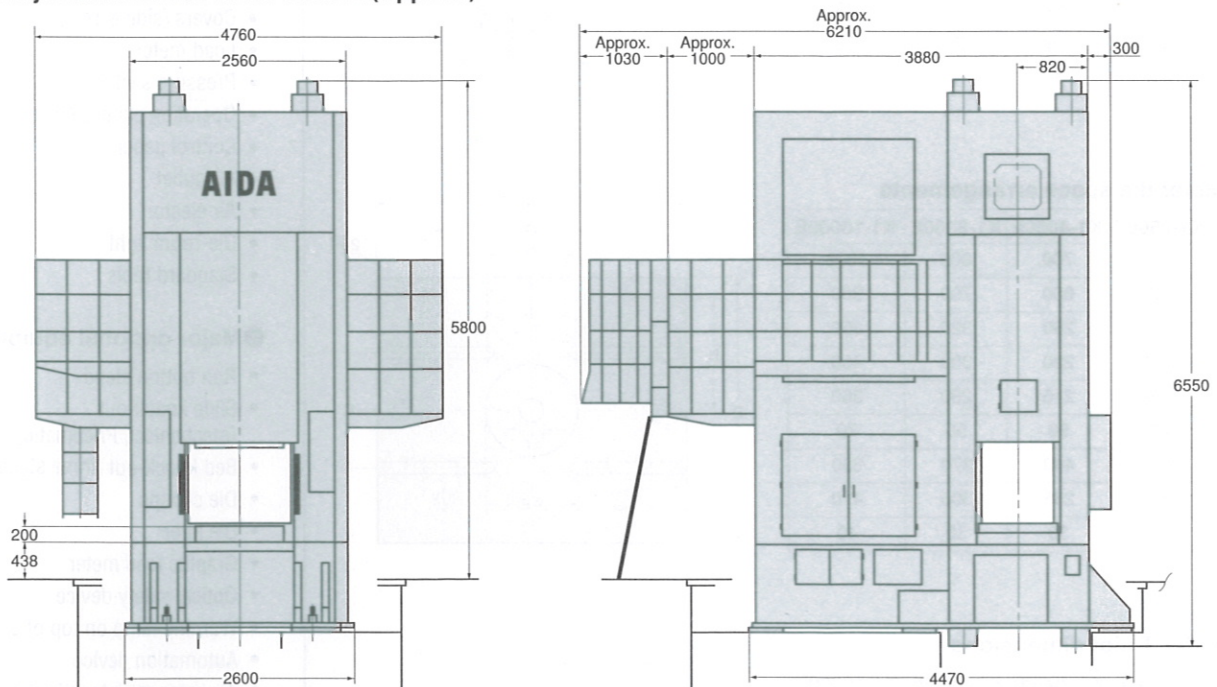
**●Major Dimensions of K1-10000E (Approx.)**

**●Principal Specifications**

Model		K1-2500E	K1-4000E	K1-6300E	K1-10000E
Tonnage capacity	(kN)	2500	4000	6300	10000
Rated tonnage point	(mm)	7	7	7	10
Slide stroke	(mm)	160	180	220	250
Strokes per minute under no load	(spm)	30~60	30~50	25~45	25~40
Die-height	(mm)	400	450	550	650
Slide adjustment	(mm)	50	50	50	50
Slide area (L.R.×F.B.)	(mm)	600×400	700×500	800×600	1000×900
Bolster area (L.R.×F.B.)	(mm)	600×500	700×600	800×700	1000×900
Side opening	(mm)	600	700	820	920
Bed Knockout capacity	(kN)	120	200	320	500
Knockout stroke	(mm)	80 (10)	90	110	110
Overall height above floor level	(mm)	3040	3555	4265	5800
Main motor	(kW)	30 V.S	37 V.S	45 V.S	DC75

※Specifications in ( ) are also available optionally.

※The specifications in this brochure are subject to change without notice.

**●Slide die space arrangements**

	K1-2500E	K1-4000E	K1-6300E	K1-10000E
A	600	700	800	1000
B	400	500	600	900
C	180	220	250	350
D	200	300	400	450
φE	186	216	280	360
φF	20	25	25	50

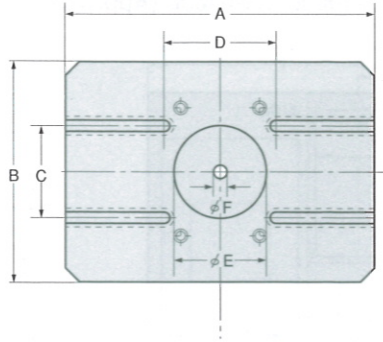
**●Slide T-slot dimensions**

	K1-2500E	K1-4000E	K1-6300E	K1-10000E
A	18	22	28	42
B	18	22	28	42
C	30	37	46	68
D	27.5	36	44	66
E	15	19	23	33
F	12	16	20	30
G	0.5	1	1	1

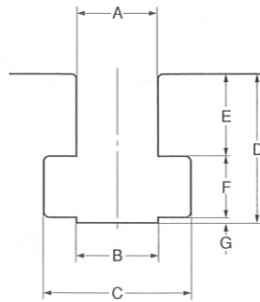
**●Bolster die space arrangements**

	K1-2500E	K1-4000E	K1-6300E	K1-10000E
A	600	700	800	1000
B	500	600	700	900
C	220	260	320	350
D	200	230	300	450
φE	186	216	280	360
φF	40	50	50	70
G	340	440	370	650
H	205	255	305	410
φI	30	30	30	40

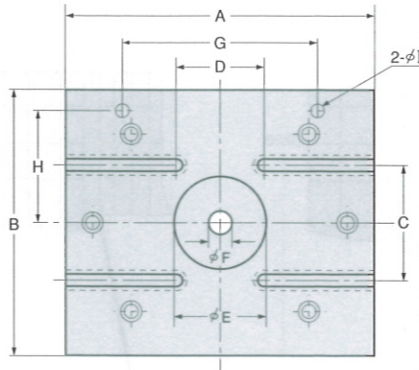
**●Bolster T-slot dimensions**

	K1-2500E	K1-4000E	K1-6300E	K1-10000E
A	28	28	28	42
B	28	28	28	42
C	46	46	46	68
D	44	44	44	66
E	23	23	23	23
F	20	20	20	32
G	1	1	1	1

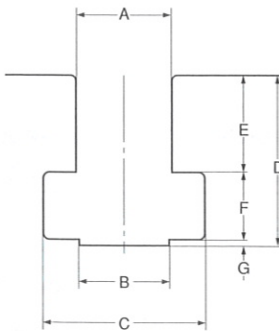

※The specifications may be changed without notice.

**●Major standard equipment**

- Variable-speed drive
- Reversing starter
- Micro-inching
- Flywheel brake
- Overload protector (PAT.)
- Electronic crank angle indicator
- Die height indicator
- Stand-type operation button box
- Insert plate
- Mechanical knock-out within the bed
- Lubrication system
- Timing switch
- Production counter
- Preset counter
- Emergency stop button
- Over-run detector
- Shutter (front)
- Covers (side & rear)
- Load meter
- Pressure switch
- Operation panel (MPC+PLC)
- Control panel
- Air outlet
- Air ejector
- Die-room light
- Standard tools

**●Major optional equipment**

- Run button stand
- Slide knock-out (mechanical, Pneumatic)
- Bed knock-out (three stage)
- Die clamps
- Die lifter
- Graphic load meter
- Optical safety device
- Warning lamp on top of press
- Automation device
- Air pressure intensification valve
- Two dimensional transfer unit (mechanical)
- Three dimensional transfer unit (servo type)
- Product discharge conveyor
- Material feed device
- Die set
- Anit-vibration mount
- Anchor bolts

※More attachments are prepared than the specifications shown above. Please contact AIDA for further information.

**AIDA ENGINEERING, LTD. (JAPAN)**

2-10 Ohyama-cho, Sagami-hara, Kanagawa 229-1181, Japan.  
 Phone: (81)42-772-5258 Facsimile: (81)42-758-1169  
 Homepage Address: <http://www.aida.co.jp/>